

FEATURES

- Extremely Easy to Use—A Single Resistor Value Sets the Cutoff Frequency ($256\text{Hz} < f_c < 256\text{kHz}$)
- Extremely Flexible—Different Resistor Values Allow Arbitrary Transfer Functions with or without Gain ($256\text{Hz} < f_c < 256\text{kHz}$)
- Supports Cutoff Frequencies Up to 360kHz Using FilterCAD™
- LTC1563-2: Unity-Gain Butterworth Response Uses a Single Resistor Value, Different Resistor Values Allow Other Responses with or without Gain
- LTC1563-3: Unity-Gain Bessel Response Uses a Single Resistor Value, Different Resistor Values Allow Other Responses with or without Gain
- Rail-to-Rail Input and Output Voltages
- Operates from a Single 3V (2.7V Min) to $\pm 5\text{V}$ Supply
- Low Noise: $36\mu\text{V}_{\text{RMS}}$ for $f_c = 25.6\text{kHz}$, $60\mu\text{V}_{\text{RMS}}$ for $f_c = 256\text{kHz}$
- f_c Accuracy $< \pm 2\%$ (Typ)
- DC Offset $< 1\text{mV}$
- Cascadable to Form 8th Order Lowpass Filters
- Available in Narrow SSOP-16 Package

APPLICATIONS

- Discrete RC Active Filter Replacement
- Antialiasing Filters
- Smoothing or Reconstruction Filters
- Linear Phase Filtering for Data Communication
- Phase Locked Loops

DESCRIPTION

The LTC®1563-2/LTC1563-3 are a family of extremely easy-to-use, active RC lowpass filters with rail-to-rail inputs and outputs and low DC offset suitable for systems with a resolution of up to 16 bits. The LTC1563-2, with a single resistor value, gives a unity-gain Butterworth response. The LTC1563-3, with a single resistor value, gives a unity-gain Bessel response. The proprietary architecture of these parts allows for a simple resistor calculation:

$$R = 10\text{k} (256\text{kHz}/f_c); f_c = \text{Cutoff Frequency}$$

where f_c is the desired cutoff frequency. For many applications, this formula is all that is needed to design a filter. By simply utilizing different valued resistors, gain and other responses are achieved.

The LTC1563-X features a low power mode, for the lower frequency applications, where the supply current is reduced by an order of magnitude and a near zero power shutdown mode.

The LTC1563-Xs are available in the narrow SSOP-16 package (Same footprint as an SO-8 package).

LT, LTC and LT are registered trademarks of Linear Technology Corporation. FilterCAD is trademark of Linear Technology Corporation. All other trademarks are the property of their respective owners.

TYPICAL APPLICATION

Single 3.3V, 256Hz to 256kHz Butterworth Lowpass Filter



Frequency Response



ABSOLUTE MAXIMUM RATINGS

(Note 1)

Total Supply Voltage (V^+ to V^-)	11V
Maximum Input Voltage at Any Pin	$(V^- - 0.3V) \leq V_{PIN} \leq (V^+ + 0.3V)$
Power Dissipation	500mW
Operating Temperature Range	
LTC1563C	0°C to 70°C
LTC1563I	-40°C to 85°C
Storage Temperature Range	-65°C to 150°C
Lead Temperature (Soldering, 10 sec)	300°C

PACKAGE/ORDER INFORMATION

<p>GN PACKAGE 16-LEAD PLASTIC SSOP</p> <p>$T_{JMAX} = 150^\circ\text{C}$, $\theta_{JA} = 135^\circ\text{C/W}$</p> <p>NOTE: PINS LABELED NC ARE NOT CONNECTED INTERNALLY AND SHOULD BE CONNECTED TO THE SYSTEM GROUND</p>	ORDER PART NUMBER
	LTC1563-2CGN LTC1563-3CGN LTC1563-2IGN LTC1563-3IGN
	GN PART MARKING
	15632 15633 15632I 15633I
Order Options Tape and Reel: Add #TR Lead Free: Add #PBF Lead Free Tape and Reel: Add #TRPBF Lead Free Part Marking: http://www.linear.com/leadfree/	

Consult LTC Marketing for Military grade parts.

ELECTRICAL CHARACTERISTICS

The ● denotes specifications which apply over the full operating temperature range, otherwise specifications are $T_A = 25^\circ\text{C}$.

$V_S = \text{Single } 4.75\text{V}$, EN pin to logic "low," Gain = 1, $R_{FIL} = R_{11} = R_{21} = R_{31} = R_{12} = R_{22} = R_{32}$, specifications apply to both the high speed (HS) and low power (LP) modes unless otherwise noted.

PARAMETER	CONDITIONS	MIN	TYP	MAX	UNITS
Specifications for Both LTC1563-2 and LTC1563-3					
Total Supply Voltage (V_S), HS Mode		● 3		11	V
Total Supply Voltage (V_S), LP Mode		● 2.7		11	V
Output Voltage Swing High (LPB Pin) HS Mode	$V_S = 3\text{V}$, $f_C = 25.6\text{kHz}$, $R_{FIL} = 100\text{k}$, $R_L = 10\text{k}$ to GND $V_S = 4.75\text{V}$, $f_C = 25.6\text{kHz}$, $R_{FIL} = 100\text{k}$, $R_L = 10\text{k}$ to GND $V_S = \pm 5\text{V}$, $f_C = 25.6\text{kHz}$, $R_{FIL} = 100\text{k}$, $R_L = 10\text{k}$ to GND	● 2.9 ● 4.55 ● 4.8	2.95 4.7 4.9		V V V
Output Voltage Swing Low (LPB Pin) HS Mode	$V_S = 3\text{V}$, $f_C = 25.6\text{kHz}$, $R_{FIL} = 100\text{k}$, $R_L = 10\text{k}$ to GND $V_S = 4.75\text{V}$, $f_C = 25.6\text{kHz}$, $R_{FIL} = 100\text{k}$, $R_L = 10\text{k}$ to GND $V_S = \pm 5\text{V}$, $f_C = 25.6\text{kHz}$, $R_{FIL} = 100\text{k}$, $R_L = 10\text{k}$ to GND	● ● ●	0.015 0.02 -4.95	0.05 0.05 -4.9	V V V
Output Swing High (LPB Pin) LP Mode	$V_S = 2.7\text{V}$, $f_C = 25.6\text{kHz}$, $R_{FIL} = 100\text{k}$, $R_L = 10\text{k}$ to GND $V_S = 4.75\text{V}$, $f_C = 25.6\text{kHz}$, $R_{FIL} = 100\text{k}$, $R_L = 10\text{k}$ to GND $V_S = \pm 5\text{V}$, $f_C = 25.6\text{kHz}$, $R_{FIL} = 100\text{k}$, $R_L = 10\text{k}$ to GND	● 2.6 ● 4.55 ● 4.8	2.65 4.65 4.9		V V V
Output Swing Low (LPB Pin) LP Mode	$V_S = 2.7\text{V}$, $f_C = 25.6\text{kHz}$, $R_{FIL} = 100\text{k}$, $R_L = 10\text{k}$ to GND $V_S = 4.75\text{V}$, $f_C = 25.6\text{kHz}$, $R_{FIL} = 100\text{k}$, $R_L = 10\text{k}$ to GND $V_S = \pm 5\text{V}$, $f_C = 25.6\text{kHz}$, $R_{FIL} = 100\text{k}$, $R_L = 10\text{k}$ to GND	● ● ●	0.01 0.015 -4.95	0.05 0.05 -4.9	V V V
DC Offset Voltage, HS Mode (Section A Only)	$V_S = 3\text{V}$, $f_C = 25.6\text{kHz}$, $R_{FIL} = 100\text{k}$ $V_S = 4.75\text{V}$, $f_C = 25.6\text{kHz}$, $R_{FIL} = 100\text{k}$ $V_S = \pm 5\text{V}$, $f_C = 25.6\text{kHz}$, $R_{FIL} = 100\text{k}$	● ● ●	± 1.5 ± 1.0 ± 1.5	± 3 ± 3 ± 3	mV mV mV
DC Offset Voltage, LP Mode (Section A Only)	$V_S = 2.7\text{V}$, $f_C = 25.6\text{kHz}$, $R_{FIL} = 100\text{k}$ $V_S = 4.75\text{V}$, $f_C = 25.6\text{kHz}$, $R_{FIL} = 100\text{k}$ $V_S = \pm 5\text{V}$, $f_C = 25.6\text{kHz}$, $R_{FIL} = 100\text{k}$	● ● ●	± 2 ± 2 ± 2	± 6 ± 6 ± 7	mV mV mV
DC Offset Voltage, HS Mode (Input to Output, Sections A, B Cascaded)	$V_S = 3\text{V}$, $f_C = 25.6\text{kHz}$, $R_{FIL} = 100\text{k}$ $V_S = 4.75\text{V}$, $f_C = 25.6\text{kHz}$, $R_{FIL} = 100\text{k}$ $V_S = \pm 5\text{V}$, $f_C = 25.6\text{kHz}$, $R_{FIL} = 100\text{k}$	● ● ●	± 1.5 ± 1.0 ± 1.5	± 3 ± 3 ± 3	mV mV mV

ELECTRICAL CHARACTERISTICS

The ● denotes specifications which apply over the full operating temperature range, otherwise specifications are $T_A = 25^\circ\text{C}$.

$V_S = \text{Single } 4.75\text{V}$, EN pin to logic "low," Gain = 1, $R_{\text{FIL}} = R_{11} = R_{21} = R_{31} = R_{12} = R_{22} = R_{32}$, specifications apply to both the high speed (HS) and low power (LP) modes unless otherwise noted.

PARAMETER	CONDITIONS		MIN	TYP	MAX	UNITS
DC Offset Voltage, LP Mode (Input to Output, Sections A, B Cascaded)	$V_S = 2.7\text{V}$, $f_C = 25.6\text{kHz}$, $R_{\text{FIL}} = 100\text{k}$	●		±2	±7	mV
	$V_S = 4.75\text{V}$, $f_C = 25.6\text{kHz}$, $R_{\text{FIL}} = 100\text{k}$	●		±2	±7	mV
	$V_S = \pm 5\text{V}$, $f_C = 25.6\text{kHz}$, $R_{\text{FIL}} = 100\text{k}$	●		±2	±8	mV
DC Offset Voltage Drift, HS Mode (Input to Output, Sections A, B Cascaded)	$V_S = 3\text{V}$, $f_C = 25.6\text{kHz}$, $R_{\text{FIL}} = 100\text{k}$	●		10		$\mu\text{V}/^\circ\text{C}$
	$V_S = 4.75\text{V}$, $f_C = 25.6\text{kHz}$, $R_{\text{FIL}} = 100\text{k}$	●		10		$\mu\text{V}/^\circ\text{C}$
	$V_S = \pm 5\text{V}$, $f_C = 25.6\text{kHz}$, $R_{\text{FIL}} = 100\text{k}$	●		10		$\mu\text{V}/^\circ\text{C}$
DC Offset Voltage Drift, LP Mode (Input to Output, Sections A, B Cascaded)	$V_S = 2.7\text{V}$, $f_C = 25.6\text{kHz}$, $R_{\text{FIL}} = 100\text{k}$	●		10		$\mu\text{V}/^\circ\text{C}$
	$V_S = 4.75\text{V}$, $f_C = 25.6\text{kHz}$, $R_{\text{FIL}} = 100\text{k}$	●		10		$\mu\text{V}/^\circ\text{C}$
	$V_S = \pm 5\text{V}$, $f_C = 25.6\text{kHz}$, $R_{\text{FIL}} = 100\text{k}$	●		10		$\mu\text{V}/^\circ\text{C}$
AGND Voltage	$V_S = 4.75\text{V}$, $f_C = 25.6\text{kHz}$, $R_{\text{FIL}} = 100\text{k}$	●	2.35	2.375	2.40	V
Power Supply Current, HS Mode	$V_S = 3\text{V}$, $f_C = 25.6\text{kHz}$, $R_{\text{FIL}} = 100\text{k}$	●		8.0	14	mA
	$V_S = 4.75\text{V}$, $f_C = 25.6\text{kHz}$, $R_{\text{FIL}} = 100\text{k}$	●		10.5	17	mA
	$V_S = \pm 5\text{V}$, $f_C = 25.6\text{kHz}$, $R_{\text{FIL}} = 100\text{k}$	●		15	23	mA
Power Supply Current, LP Mode	$V_S = 2.7\text{V}$, $f_C = 25.6\text{kHz}$, $R_{\text{FIL}} = 100\text{k}$	●		1.0	1.8	mA
	$V_S = 4.75\text{V}$, $f_C = 25.6\text{kHz}$, $R_{\text{FIL}} = 100\text{k}$	●		1.4	2.5	mA
	$V_S = \pm 5\text{V}$, $f_C = 25.6\text{kHz}$, $R_{\text{FIL}} = 100\text{k}$	●		2.3	3.5	mA
Shutdown Mode Supply Current	$V_S = 4.75\text{V}$, $f_C = 25.6\text{kHz}$, $R_{\text{FIL}} = 100\text{k}$	●		1	20	μA
EN Input Logic Low Level	$V_S = 3\text{V}$	●			0.8	V
	$V_S = 4.75\text{V}$	●			1	V
	$V_S = \pm 5\text{V}$	●			1	V
EN Input Logic High Level	$V_S = 3\text{V}$	●	2.5			V
	$V_S = 4.75\text{V}$	●	4.3			V
	$V_S = \pm 5\text{V}$	●	4.4			V
LP Logic Low Level	$V_S = 3\text{V}$	●			0.8	V
	$V_S = 4.75\text{V}$	●			1	V
	$V_S = \pm 5\text{V}$	●			1	V
LP Logic High Level	$V_S = 3\text{V}$	●	2.5			V
	$V_S = 4.75\text{V}$	●	4.3			V
	$V_S = \pm 5\text{V}$	●	4.4			V

LTC1563-2 Transfer Function Characteristics

Cutoff Frequency Range, f_C HS Mode (Note 2)	$V_S = 3\text{V}$	●	0.256		256	kHz
	$V_S = 4.75\text{V}$	●	0.256		256	kHz
	$V_S = \pm 5\text{V}$	●	0.256		256	kHz
Cutoff Frequency Range, f_C LP Mode (Note 2)	$V_S = 2.7\text{V}$	●	0.256		25.6	kHz
	$V_S = 4.75\text{V}$	●	0.256		25.6	kHz
	$V_S = \pm 5\text{V}$	●	0.256		25.6	kHz
Cutoff Frequency Accuracy, HS Mode $f_C = 25.6\text{kHz}$	$V_S = 3\text{V}$, $R_{\text{FIL}} = 100\text{k}$	●	-2.0	±1.5	3.5	%
	$V_S = 4.75\text{V}$, $R_{\text{FIL}} = 100\text{k}$	●	-2.0	±1.5	3.5	%
	$V_S = \pm 5\text{V}$, $R_{\text{FIL}} = 100\text{k}$	●	-2.0	±1.5	3.5	%
Cutoff Frequency Accuracy, HS Mode $f_C = 256\text{kHz}$	$V_S = 3\text{V}$, $R_{\text{FIL}} = 10\text{k}$	●	-5	±1.5	2.5	%
	$V_S = 4.75\text{V}$, $R_{\text{FIL}} = 10\text{k}$	●	-5	±1.5	2.5	%
	$V_S = \pm 5\text{V}$, $R_{\text{FIL}} = 10\text{k}$	●	-5	±1.5	2.5	%
Cutoff Frequency Accuracy, LP Mode $f_C = 25.6\text{kHz}$	$V_S = 2.7\text{V}$, $R_{\text{FIL}} = 100\text{k}$	●	-3	±1.5	3	%
	$V_S = 4.75\text{V}$, $R_{\text{FIL}} = 100\text{k}$	●	-3	±1.5	3	%
	$V_S = \pm 5\text{V}$, $R_{\text{FIL}} = 100\text{k}$	●	-3	±1.5	3	%
Cutoff Frequency Temperature Coefficient	(Note 3)	●		±1		ppm/ $^\circ\text{C}$

ELECTRICAL CHARACTERISTICS

The ● denotes specifications which apply over the full operating temperature range, otherwise specifications are $T_A = 25^\circ\text{C}$.

$V_S = \text{Single } 4.75\text{V}$, $\overline{\text{EN}}$ pin to logic "low," Gain = 1, $R_{\text{FIL}} = R11 = R21 = R31 = R12 = R22 = R32$, specifications apply to both the high speed (HS) and low power (LP) modes unless otherwise noted.

PARAMETER	CONDITIONS		MIN	TYP	MAX	UNITS
Passband Gain, HS Mode, $f_C = 25.6\text{kHz}$ $V_S = 4.75\text{V}$, $R_{\text{FIL}} = 100\text{k}$	Test Frequency = 2.56kHz ($0.1 \cdot f_C$)	●	-0.2	0	0.2	dB
	Test Frequency = 12.8kHz ($0.5 \cdot f_C$)	●	-0.3	0	0.3	dB
Stopband Gain, HS Mode, $f_C = 25.6\text{kHz}$ $V_S = 4.75\text{V}$, $R_{\text{FIL}} = 100\text{k}$	Test Frequency = 51.2kHz ($2 \cdot f_C$)	●		-24	-21.5	dB
	Test Frequency = 102.4kHz ($4 \cdot f_C$)	●		-48	-46	dB
Passband Gain, HS Mode, $f_C = 256\text{kHz}$ $V_S = 4.75\text{V}$, $R_{\text{FIL}} = 10\text{k}$	Test Frequency = 25.6kHz ($0.1 \cdot f_C$)	●	-0.2	0	0.2	dB
	Test Frequency = 128kHz ($0.5 \cdot f_C$)	●	-0.5	0	0.5	dB
Stopband Gain, HS Mode, $f_C = 256\text{kHz}$ $V_S = 4.75\text{V}$, $R_{\text{FIL}} = 10\text{k}$	Test Frequency = 400kHz ($1.56 \cdot f_C$)	●		-15.7	-13.5	dB
	Test Frequency = 500kHz ($1.95 \cdot f_C$)	●		-23.3	-21.5	dB
Passband Gain, LP Mode, $f_C = 25.6\text{kHz}$ $V_S = 4.75\text{V}$, $R_{\text{FIL}} = 100\text{k}$	Test Frequency = 2.56kHz ($0.1 \cdot f_C$)	●	-0.25	0	0.25	dB
	Test Frequency = 12.8kHz ($0.5 \cdot f_C$)	●	-0.6	-0.02	0.6	dB
Stopband Gain, LP Mode, $f_C = 25.6\text{kHz}$ $V_S = 4.75\text{V}$, $R_{\text{FIL}} = 100\text{k}$	Test Frequency = 51.2kHz ($2 \cdot f_C$)	●		-24	-22	dB
	Test Frequency = 102.4kHz ($4 \cdot f_C$)	●		-48	-46.5	dB

LTC1563-3 Transfer Function Characteristics

Cutoff Frequency Range, f_C HS Mode (Note 2)	$V_S = 3\text{V}$	●	0.256		256	kHz
	$V_S = 4.75\text{V}$	●	0.256		256	kHz
	$V_S = \pm 5\text{V}$	●	0.256		256	kHz
Cutoff Frequency Range, f_C LP Mode (Note 2)	$V_S = 2.7\text{V}$	●	0.256		25.6	kHz
	$V_S = 4.75\text{V}$	●	0.256		25.6	kHz
	$V_S = \pm 5\text{V}$	●	0.256		25.6	kHz
Cutoff Frequency Accuracy, HS Mode $f_C = 25.6\text{kHz}$	$V_S = 3\text{V}$, $R_{\text{FIL}} = 100\text{k}$	●	-3	± 2	5.5	%
	$V_S = 4.75\text{V}$, $R_{\text{FIL}} = 100\text{k}$	●	-3	± 2	5.5	%
	$V_S = \pm 5\text{V}$, $R_{\text{FIL}} = 100\text{k}$	●	-3	± 2	5.5	%
Cutoff Frequency Accuracy, HS Mode $f_C = 256\text{kHz}$	$V_S = 3\text{V}$, $R_{\text{FIL}} = 10\text{k}$	●	-3	± 2	6	%
	$V_S = 4.75\text{V}$, $R_{\text{FIL}} = 10\text{k}$	●	-3	± 2	6	%
	$V_S = \pm 5\text{V}$, $R_{\text{FIL}} = 10\text{k}$	●	-3	± 2	6	%
Cutoff Frequency Accuracy, LP Mode $f_C = 25.6\text{kHz}$	$V_S = 2.7\text{V}$, $R_{\text{FIL}} = 100\text{k}$	●	-4	± 3	7	%
	$V_S = 4.75\text{V}$, $R_{\text{FIL}} = 100\text{k}$	●	-4	± 3	7	%
	$V_S = \pm 5\text{V}$, $R_{\text{FIL}} = 100\text{k}$	●	-4	± 3	7	%
Cutoff Frequency Temperature Coefficient	(Note 3)	●		± 1		ppm/ $^\circ\text{C}$
Passband Gain, HS Mode, $f_C = 25.6\text{kHz}$ $V_S = 4.75\text{V}$, $R_{\text{FIL}} = 100\text{k}$	Test Frequency = 2.56kHz ($0.1 \cdot f_C$)	●	-0.2	-0.03	0.2	dB
	Test Frequency = 12.8kHz ($0.5 \cdot f_C$)	●	-1.0	-0.72	-0.25	dB
Stopband Gain, HS Mode, $f_C = 25.6\text{kHz}$ $V_S = 4.75\text{V}$, $R_{\text{FIL}} = 100\text{k}$	Test Frequency = 51.2kHz ($2 \cdot f_C$)	●		-13.6	-10	dB
	Test Frequency = 102.4kHz ($4 \cdot f_C$)	●		-34.7	-31	dB
Passband Gain, HS Mode, $f_C = 256\text{kHz}$ $V_S = 4.75\text{V}$, $R_{\text{FIL}} = 10\text{k}$	Test Frequency = 25.6kHz ($0.1 \cdot f_C$)	●	-0.2	-0.03	0.2	dB
	Test Frequency = 128kHz ($0.5 \cdot f_C$)	●	-1.1	-0.72	-0.5	dB
Stopband Gain, HS Mode, $f_C = 256\text{kHz}$ $V_S = 4.75\text{V}$, $R_{\text{FIL}} = 10\text{k}$	Test Frequency = 400kHz ($1.56 \cdot f_C$)	●		-8.3	-6	dB
	Test Frequency = 500kHz ($1.95 \cdot f_C$)	●		-13	-10.5	dB
Passband Gain, LP Mode, $f_C = 25.6\text{kHz}$ $V_S = 4.75\text{V}$, $R_{\text{FIL}} = 100\text{k}$	Test Frequency = 2.56kHz ($0.1 \cdot f_C$)	●	-0.2	-0.03	0.2	dB
	Test Frequency = 12.8kHz ($0.5 \cdot f_C$)	●	-1.0	-0.72	-0.25	dB
Stopband Gain, LP Mode, $f_C = 25.6\text{kHz}$ $V_S = 4.75\text{V}$, $R_{\text{FIL}} = 100\text{k}$	Test Frequency = 51.2kHz ($2 \cdot f_C$)	●		-13.6	-11	dB
	Test Frequency = 102.4kHz ($4 \cdot f_C$)	●		-34.7	-32	dB

Note 1: Absolute Maximum Ratings are those value beyond which the life of a device may be impaired.

Note 2: The minimum cutoff frequency of the LTC1563 is arbitrarily listed as 256Hz. The limit is arrived at by setting the maximum resistor value limit at $10\text{M}\Omega$. The LTC1563 can be used with even larger valued resistors. When using very large values of resistance careful layout and thorough

assembly practices are required. There may also be greater DC offset at high temperatures when using such large valued resistors.

Note 3: The cutoff frequency temperature drift at low frequencies is as listed. At higher cutoff frequencies (approaching 25.6kHz in low power mode and approaching 256kHz in high speed mode) the internal amplifier's bandwidth can effect the cutoff frequency. At these limits the cutoff frequency temperature drift is $\pm 15\text{ppm}/^\circ\text{C}$.

TYPICAL PERFORMANCE CHARACTERISTICS

Output Voltage Swing High vs Load Resistance



Output Voltage Swing High vs Load Resistance



Output Voltage Swing High vs Load Resistance



Output Voltage Swing Low vs Load Resistance



Output Voltage Swing Low vs Load Resistance



Output Voltage Swing Low vs Load Resistance



THD + Noise vs Input Voltage



THD + Noise vs Input Voltage



THD + Noise vs Input Voltage



TYPICAL PERFORMANCE CHARACTERISTICS

THD + Noise vs Input Frequency



THD + Noise vs Input Frequency



THD + Noise vs Input Frequency



THD + Noise vs Input Frequency



THD + Noise vs Input Frequency



THD + Noise vs Input Frequency



THD + Noise vs Input Frequency



THD + Noise vs Input Frequency



THD + Noise vs Input Frequency



TYPICAL PERFORMANCE CHARACTERISTICS

THD + Noise vs Output Load



1563 G19

THD + Noise vs Output Load



1563 G20

Output Voltage Noise vs Cutoff Frequency



1563 G21

THD + Noise vs Output Load



1563 G22

THD + Noise vs Output Load

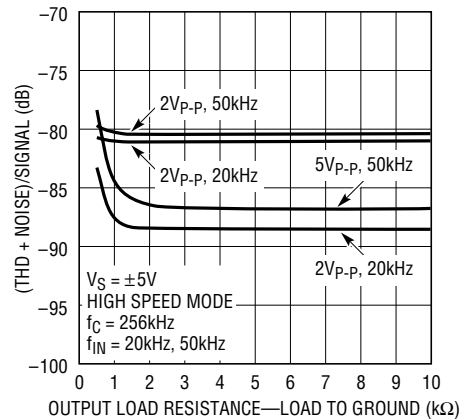

1563 G23

Stopband Gain vs Input Frequency

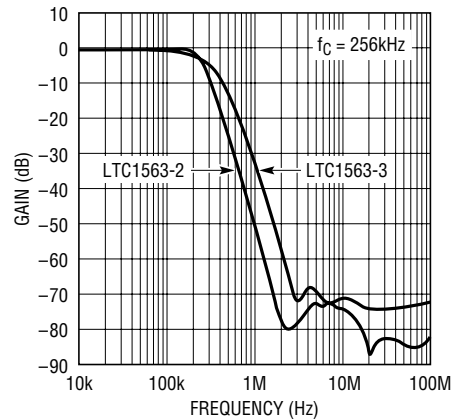

1563 G24

Crosstalk Rejection vs Frequency

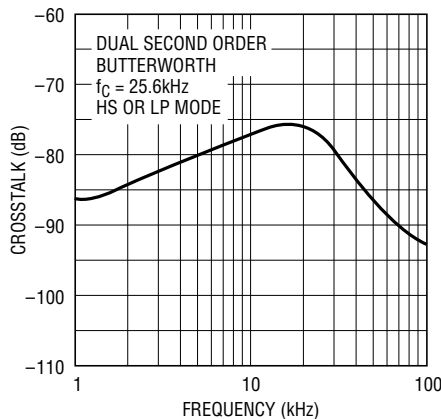

1563 G25

Crosstalk Rejection vs Frequency



1563 G26

PIN FUNCTIONS

$\overline{\text{LP}}$ (Pin 1): Low Power. The LTC1563-X has two operating modes: Low Power and High Speed. Most applications will use the High Speed operating mode. Some lower frequency, lower gain applications can take advantage of the Low Power mode. When placed in the Low Power mode, the supply current is nearly an order of magnitude lower than the High Speed mode. Refer to the Applications Information section for more information on the Low Power mode.

The LTC1563-X is in the High Speed mode when the $\overline{\text{LP}}$ input is at a logic high level or is open-circuited. A small pull-up current source at the $\overline{\text{LP}}$ input defaults the LTC1563-X to the High Speed mode if the pin is left open. The part is in the Low Power mode when the pin is pulled to a logic low level or connected to V^- .

SA, SB (Pins 2, 11): Summing Pins. These pins are a summing point for signals fed forward and backward. Capacitance on the SA or SB pin will cause excess peaking of the frequency response near the cutoff frequency. The three external resistors for each section should be located as close as possible to the summing pin to minimize this effect. Refer to the Applications Information section for more details.

NC (Pins 3, 5, 10, 12, 14): These pins are not connected internally. For best performance, they should be connected to ground.

INVA, INVB (Pins 4, 13): Inverting Input. Each of the INV pins is an inverting input of an op amp. Note that the INV pins are high impedance, sensitive nodes of the filter and very susceptible to coupling of unintended signals. Capacitance on the INV nodes will also affect the frequency response of the filter sections. For these reasons, printed circuit connections to the INV pins must be kept as short as possible.

LPA, LPB (Pins 6, 15): Lowpass Output. These pins are the rail-to-rail outputs of an op amp. Each output is designed to drive a nominal net load of 5k Ω and 20pF. Refer to the Applications Information section for more details on output loading effects.

AGND (Pin 7): Analog Ground. The AGND pin is the midpoint of an internal resistive voltage divider developing a potential halfway between the V^+ and V^- pins. The equivalent series resistance is nominally 10k Ω . This serves as an internal ground reference. Filter performance will reflect the quality of the analog signal ground. An analog ground plane surrounding the package is recommended. The analog ground plane should be connected to any digital ground at a single point. Figures 1 and 2 show the proper connections for dual and single supply operation.

V^- , V^+ (Pins 8, 16): The V^- and V^+ pins should be bypassed with 0.1 μF capacitors to an adequate analog ground or ground plane. These capacitors should be connected as closely as possible to the supply pins. Low noise linear supplies are recommended. Switching supplies are not recommended as they will decrease the filter's dynamic range. Refer to Figures 1 and 2 for the proper connections for dual and single supply operation.

$\overline{\text{EN}}$ (Pin 9): $\overline{\text{ENABLE}}$. When the $\overline{\text{EN}}$ input goes high or is open-circuited, the LTC1563-X enters a shutdown state and only junction leakage currents flow. The AGND pin, the LPA output and the LPB output assume high impedance states. If an input signal is applied to a complete filter circuit while the LTC1563-X is in shutdown, some signal will normally flow to the output through passive components around the inactive part.

A small internal pull-up current source at the $\overline{\text{EN}}$ input defaults the LTC1563 to the shutdown state if the $\overline{\text{EN}}$ pin is left floating. Therefore, the user *must* connect the $\overline{\text{EN}}$ pin to V^- (or a logic low) to enable the part for normal operation.

PIN FUNCTIONS

Dual Supply Power and Ground Connections

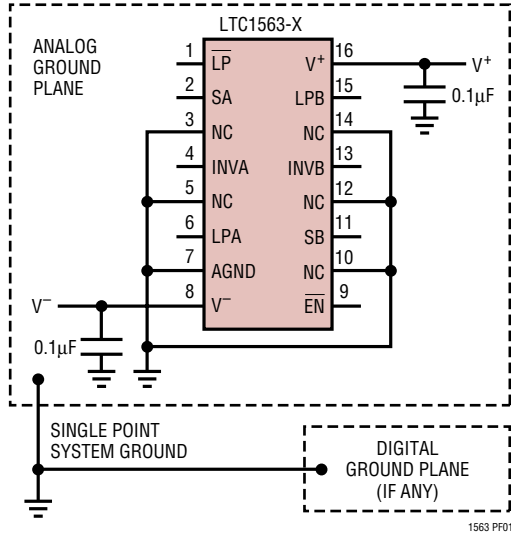

Single Supply Power and Ground Connections

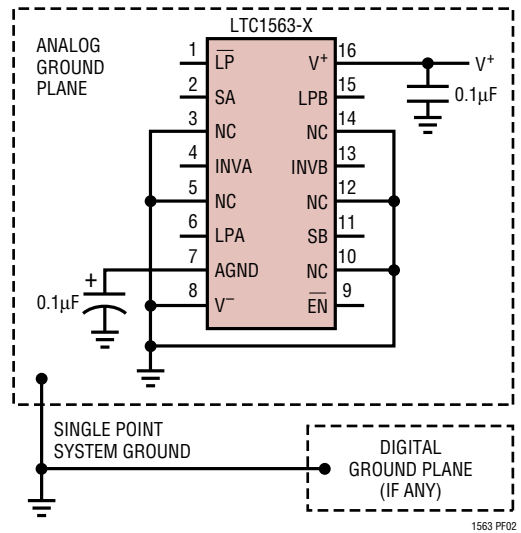

BLOCK DIAGRAM

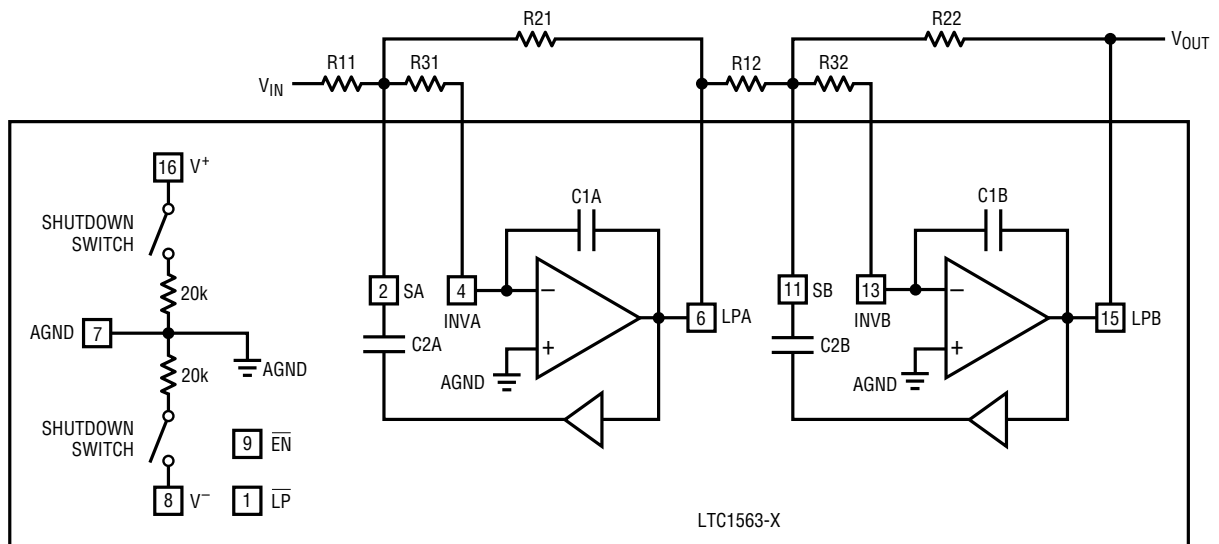

PATENT PENDING

1563 BD

APPLICATIONS INFORMATION

Functional Description

The LTC1563-2/LTC1563-3 are a family of easy-to-use, 4th order lowpass filters with rail-to-rail operation. The LTC1563-2, with a single resistor value, gives a unity-gain filter approximating a Butterworth response. The LTC1563-3, with a single resistor value, gives a unity-gain filter approximating a Bessel (linear phase) response. The proprietary architecture of these parts allows for a simple unity-gain resistor calculation:

$$R = 10k(256kHz/f_C)$$

where f_C is the desired cutoff frequency. For many applications, this formula is all that is needed to design a filter. For example, a 50kHz filter requires a 51.2k resistor. In practice, a 51.1k resistor would be used as this is the closest E96, 1% value available.

The LTC1563-X is constructed with two 2nd order sections. The output of the first section (section A) is simply fed into the second section (section B). Note that section A and section B are similar, but not identical. The parts are designed to be simple and easy to use.

By simply utilizing different valued resistors, gain, other transfer functions and higher cutoff frequencies are achieved. For these applications, the resistor value calculation gets more difficult. The tables of formulas provided later in this section make this task much easier. For best results, design these filters using FilterCAD Version 3.0 (or newer) or contact the Linear Technology Filter Applications group for assistance.

Cutoff Frequency (f_C) and Gain Limitations

The LTC1563-X has both a maximum f_C limit and a minimum f_C limit. The maximum f_C limit (256kHz in High Speed mode and 25.6kHz in the Low Power mode) is set by the speed of the LTC1563-X's op amps. At the maximum f_C , the gain is also limited to unity.

A minimum f_C is dictated by the practical limitation of reliably obtaining large valued, precision resistors. As the desired f_C decreases, the resistor value required increases. When f_C is 256Hz, the resistors are 10M. Obtaining a reliable, precise 10M resistance between two points on a printed circuit board is somewhat difficult. For example, a 10M resistor with only 200M Ω of stray, layout related

resistance in parallel, yields a net effective resistance of 9.52M and an error of -5% . Note that the gain is also limited to unity at the minimum f_C .

At intermediate f_C , the gain is limited by one of the two reasons discussed above. For best results, design filters with gain using FilterCAD Version 3 (or newer) or contact the Linear Technology Filter Applications Group for assistance.

While the simple formula and the tables in the applications section deliver good approximations of the transfer functions, a more accurate response is achieved using FilterCAD. FilterCAD calculates the resistor values using an accurate and complex algorithm to account for parasitics and op amp limitations. A design using FilterCAD will always yield the best possible design. By using the FilterCAD design tool you can also achieve filters with cutoff frequencies beyond 256kHz. Cutoff frequencies up to 360kHz are attainable.

Contact the Linear Technology Filter Applications Group for a copy the FilterCAD software. FilterCAD can also be downloaded from our website at www.linear.com.

DC Offset, Noise and Gain Considerations

The LTC1563-X is DC offset trimmed in a 2-step manner. First, section A is trimmed for minimum DC offset. Next, section B is trimmed to minimize the total DC offset (section A *plus* section B). This method is used to give the minimum DC offset in unity gain applications and most higher gain applications.

For gains greater than unity, the gain should be distributed such that most of the gain is taken in section A, with section B at a lower gain (preferably unity). This type of gain distribution results in the lowest noise and lowest DC offset. For high gain, low frequency applications, all of the gain is taken in section A, with section B set for unity-gain. In this configuration, the noise and DC offset is dominated by those of section A. At higher frequencies, the op amps' finite bandwidth limits the amount of gain that section A can reliably achieve. The gain is more evenly distributed in this case. The noise and DC offset of section A is now multiplied by the gain of section B. The result is slightly higher noise and offset.

APPLICATIONS INFORMATION

Output Loading: Resistive and Capacitive

The op amps of the LTC1563-X have a rail-to-rail output stage. To obtain maximum performance, the output loading effects must be considered. Output loading issues can be divided into resistive effects and capacitive effects.

Resistive loading affects the maximum output signal swing and signal distortion. If the output load is excessive, the output swing is reduced and distortion is increased. All of the output voltage swing testing on the LTC1563-X is done with $R_{22} = 100k$ and a 10k load resistor. For best undistorted output swing, the output load resistance should be greater than 10k.

Capacitive loading on the output reduces the stability of the op amp. If the capacitive loading is sufficiently high, the stability margin is decreased to the point of oscillation at the output. Capacitive loading should be kept below 30pF. Good, tight layout techniques should be maintained at all times. These parts should not drive long traces and must never drive a long coaxial cable. *When probing the LTC1563-X, always use a 10x probe. Never use a 1x probe.* A standard 10x probe has a capacitance of 10pF to 15pF while a 1x probe's capacitance can be as high as 150pF. The use of a 1x probe will probably cause oscillation.

For larger capacitive loads, a series isolation resistor can be used between the part and the capacitive load. If the load is too great, a buffer must be used.

Layout Precautions

The LTC1563-X is an active RC filter. The response of the filter is determined by the on-chip capacitors and the external resistors. Any external, stray capacitance in parallel with an on-chip capacitor, or to an AC ground, can alter the transfer function.

Capacitance to an AC ground is the most likely problem. Capacitance on the LPA or LPB pins does not affect the transfer function but does affect the stability of the op amps. Capacitance on the INVA and INVB pins will affect the transfer function somewhat and will also affect the stability of the op amps. Capacitance on the SA and SB pins alters the transfer function of the filter. These pins are the most sensitive to stray capacitance. Stray capacitance on these pins results in peaking of the frequency response

near the cutoff frequency. Poor layout can give 0.5dB to 1dB of excess peaking.

To minimize the effects of parasitic layout capacitance, all of the resistors for section A should be placed as close as possible to the SA pin. Place the R31 resistor first so that it is as close as possible to the SA pin on one end and as close as possible to the INVA pin on the other end. Use the same strategy for the layout of section B, keeping all of the resistors as close as possible to the SB node and first placing R32 between the SB and INVB pins. It is also best if the signal routing and resistors are on the same layer as the part without any vias in the signal path.

Figure 1 illustrates a good layout using the LTC1563-X with surface mount 0805 size resistors. An even tighter layout is possible with smaller resistors.

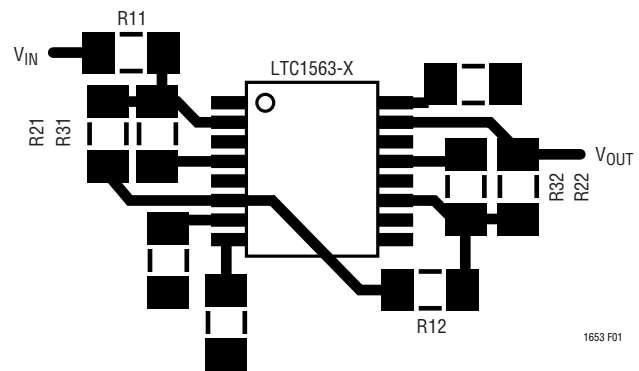

Figure 1. PC Board Layout

Single Pole Sections and Odd Order Filters

The LTC1563 is configured to naturally form even ordered filters (2nd, 4th, 6th and 8th). With a little bit of work, single pole sections and odd order filters are easily achieved. To form a single pole section you simply use the op amp, the on-chip C1 capacitor and two external resistors as shown in Figure 2. This gives an inverting section with the gain set by the R2-R1 ratio and the pole set by the R2-C1 time constant. You can use this pole with a 2nd order section to form a noninverting gain 3rd order filter or as a stand alone inverting gain single pole filter.

Figure 3 illustrates another way of making odd order filters. The R1 input resistor is split into two parts with an additional capacitor connected to ground in between the resistors. This "TEE" network forms a single real pole. RB1

156323fa

APPLICATIONS INFORMATION

should be much larger than RA1 to minimize the interaction of this pole with the 2nd order section. This circuit is useful in forming dual 3rd order filters and 5th order filters with a single LTC1563 part. By cascading two parts, 7th order and 9th order filters are achieved.

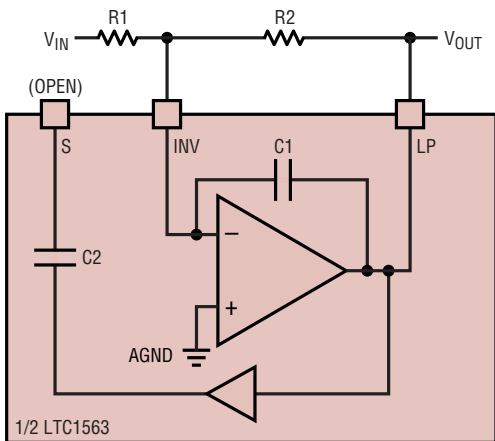

$$\text{DC GAIN} = \frac{-R2}{R1}$$

$$F_p = \frac{1}{2\pi \cdot R2 \cdot C1}$$

LTC1563-2: C1A = 53.9pF, C1B = 39.2pF
 LTC1563-3: C1A = 35pF, C1B = 26.8pF

Figure 2

You can also use the TEE network in both sections of the part to make a 6th order filter. This 6th order filter does not conform exactly to the textbook responses. Textbook responses (Butterworth, Bessel, Chebyshev etc.) all have three complex pole pairs. This filter has two complex pole pairs and two real poles. The textbook response always has one section with a low Q value between 0.5 and 0.6. By replacing this low Q section with two real poles (two real poles are the same mathematically as a complex pole pair with a Q of 0.5) and tweaking the Q of the other two complex pole pair sections you end up with a filter that is indistinguishable from the textbook filter. The Typical Applications section illustrates a 100kHz, 6th order pseudo-Butterworth filter. FilterCAD is a valuable tool for custom filter design and tweaking textbook responses.



$$RA1 = \frac{RB1}{10}$$

$$F_p = \frac{1}{2\pi \cdot \left(\frac{RA1 \cdot RB1}{RA1 + RB1} \right) C_p}$$

Figure 3

What To Do with an Unused Section

If the LTC1563 is used as a 2nd or 3rd order filter, one of the sections is not used. Do not leave this section unconnected. If the section is left unconnected, the output is left to float and oscillation may occur. The unused section should be connected as shown in Figure 4 with the INV pin connected to the LP pin and the S pin left open.



Figure 4

APPLICATIONS INFORMATION

4th Order Filter Responses Using the LTC1563-2



Figure 5. 4th Order Filter Connections (Power Supply, Ground, EN and LP Connections Not Shown for Clarity). Table 1 Shows Resistor Values



Figure 5a. Frequency Response



Figure 5b. Passband Frequency Response



Figure 5c. Step Response

Table 1. Resistor Values, Normalized to 256kHz Cutoff Frequency (f_c), Figure 5. The Passband Gain, of the 4th Order LTC1563-2 Lowpass Filter, Is Set to Unity. (Note 1)

	BUTTERWORTH	0.1dB RIPPLE CHEBYSHEV	0.5dB RIPPLE CHEBYSHEV
LP Mode Max f_c	25.6kHz	15kHz	13kHz
HS Mode Max f_c	256kHz	135kHz	113kHz
R11 = R21 =	10k(256kHz/ f_c)	13.7k(256kHz/ f_c)	20.5k(256kHz/ f_c)
R31 =	10k(256kHz/ f_c)	10.7k(256kHz/ f_c)	12.4k(256kHz/ f_c)
R12 = R22 =	10k(256kHz/ f_c)	10k(256kHz/ f_c)	12.1k(256kHz/ f_c)
R32 =	10k(256kHz/ f_c)	6.81k(256kHz/ f_c)	6.98k(256kHz/ f_c)

Example: In HS mode, 0.1dB ripple Chebyshev, 100kHz cutoff frequency, R11 = R21 = 35k \approx 34.8k (1%), R31 = 27.39k \approx 27.4k (1%), R12 = R22 = 256k \approx 255k (1%), R32 = 17.43k \approx 17.4k (1%)

Note 1: The resistor values listed in this table provide good approximations of the listed transfer functions. For the optimal resistor values, higher gain or other transfer functions, use FilterCAD Version 3.0 (or newer) or contact the Linear Technology Filter Applications group for assistance.

APPLICATIONS INFORMATION

4th Order Filter Responses Using the LTC1563-3

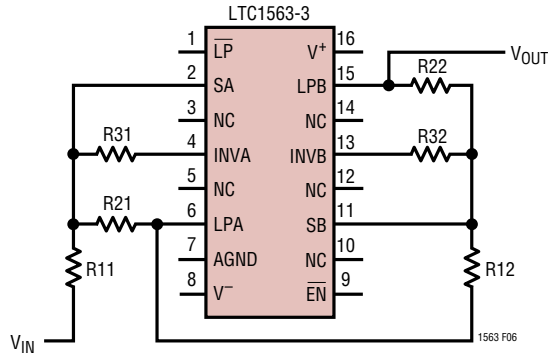

Figure 6. 4th Order Filter Connections (Power Supply, Ground, EN and LP Connections Not Shown for Clarity). Table 2 Shows Resistor Values

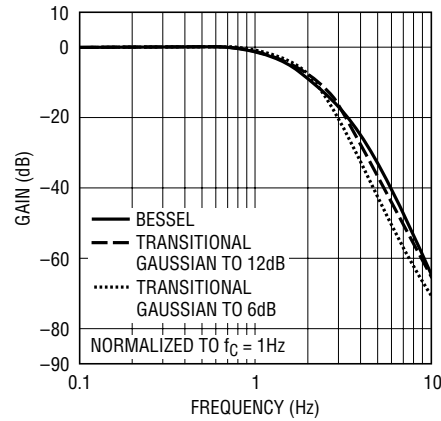

Figure 6a. Frequency Response

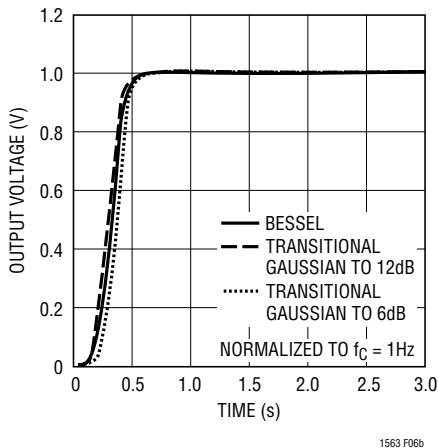

Figure 6b. Step Response

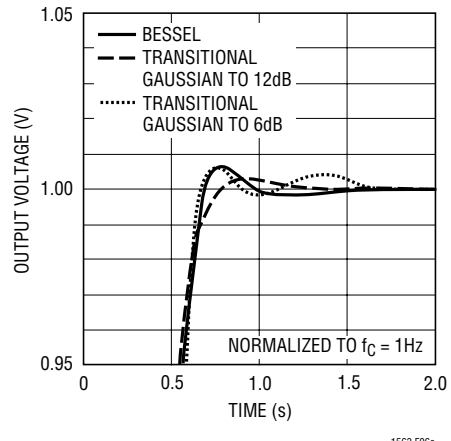

Figure 6c. Step Response—Settling

Table 2. Resistor Values, Normalized to 256kHz Cutoff Frequency (f_C), Figure 6. The Passband Gain, of the 4th Order LTC1563-3 Lowpass Filter, Is Set to Unity. (Note 1)

	BESSEL	TRANSITIONAL GAUSSIAN TO 6dB	TRANSITIONAL GAUSSIAN TO 12dB
LP Mode Max f_C	25.6kHz	20kHz	21kHz
HS Mode Max f_C	256kHz	175kHz	185kHz
R11 = R21 =	10k(256kHz/ f_C)	17.4k(256kHz/ f_C)	15k(256kHz/ f_C)
R31 =	10k(256kHz/ f_C)	13.3k(256kHz/ f_C)	11.8k(256kHz/ f_C)
R12 = R22 =	10k(256kHz/ f_C)	14.3k(256kHz/ f_C)	10.5k(256kHz/ f_C)
R32 =	10k(256kHz/ f_C)	6.04k(256kHz/ f_C)	6.19k(256kHz/ f_C)

Note 1: The resistor values listed in this table provide good approximations of the listed transfer functions. For the optimal resistor values, higher gain or other transfer functions, use FilterCAD Version 3.0 (or newer) or contact the Linear Technology Filter Applications group for assistance.

TYPICAL APPLICATIONS

±5V, 2.3mA Supply Current, 20kHz, 4th Order, 0.5dB Ripple Chebyshev Lowpass Filter



Frequency Response



1563 TA04

Single 3.3V, 2mA Supply Current, 20kHz 8th Order Butterworth Lowpass Filter



Frequency Response



1563 TA06

156323fa

TYPICAL APPLICATIONS

100kHz, 6th Order Pseudo-Butterworth

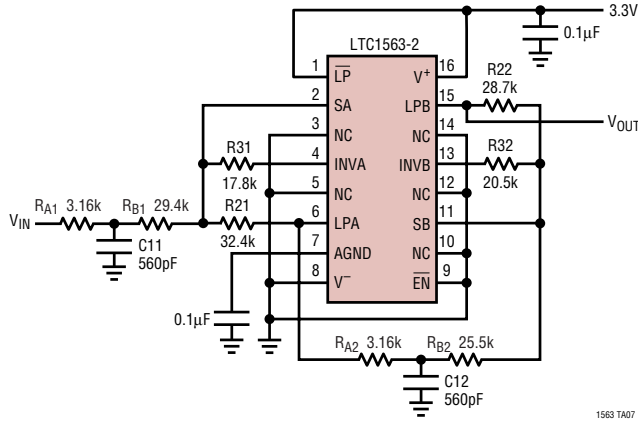

Frequency Response

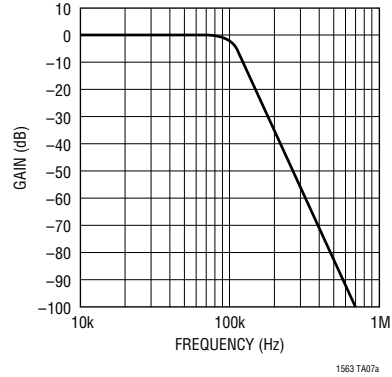

TEXTBOOK BUTTERWORTH		PSEUDO-BUTTERWORTH	
$f_{01} = 100\text{kHz}$	$Q1 = 1.9319$	$f_{01} = 100\text{kHz}$	$Q1 = 1.9319$
$f_{02} = 100\text{kHz}$	$Q2 = 0.7071$	$f_{02} = 100\text{kHz}$	$Q2 = 0.7358$
$f_{03} = 100\text{kHz}$	$Q3 = 0.5176$	$f_{03} = 100\text{kHz}$	Real Poles
		$f_{04} = 100\text{kHz}$	Real Poles

The complex, 2nd order section of the textbook design with the lowest Q is replaced with two real first order poles. The Q of another section is slightly altered such that the final filter's response is indistinguishable from a textbook Butterworth response.

Other Pseudo Filter Response Coefficients (All f_0 Are Normalized for a 1Hz Filter Cutoff)

	BESSEL	0.1dB RIPPLE CHEBYSHEV	0.5dB RIPPLE CHEBYSHEV	TRANSITIONAL GAUSSIAN TO 12dB	TRANSITIONAL GAUSSIAN TO 6dB
f_{01}	1.9070	1.0600	1.0100	2.1000	1.5000
$Q1$	1.0230	3.8500	5.3000	2.2000	2.8500
f_{02}	1.6910	0.8000	0.7200	1.2500	1.0500
$Q2$	0.6110	1.0000	1.2000	0.8000	0.9000
f_{03}	1.6060	0.6000	0.5000	1.2500	0.9000
f_{04}	1.6060	1.0000	0.8000	1.2500	0.9000

The f_0 and Q values listed above can be entered in FilterCAD's Enhanced Design window as a custom response filter. After entering the coefficients, FilterCAD will produce a schematic of the circuit. The procedure is as follows:

1. After starting FilterCAD, select the Enhanced Design window.
2. Select the Custom Response and set the custom F_C to 1Hz.
3. In the Coefficients table, go to the Type column and click on the types listed and set the column with two LP types and two LP1 types. This sets up a template of a 6th order filter with two 2nd order lowpass sections and two 1st order lowpass sections.
4. Enter the f_0 and Q coefficients as listed above. For a Butterworth filter, use the same coefficients as the example circuit above except set all of the f_0 to 1Hz.
5. Set the custom F_C to the desired cutoff frequency. This will automatically multiply all of the f_0 coefficients. You have now finished the design of the filter and you can click on the frequency response or step response buttons to verify the filter's response.
6. Click on the Implement button to go on to the filter implementation stage.
7. In the Enhanced Implement window, click on the Active RC button to choose the LTC1563-2 part. You are now done with the filter's implementation. Click on the schematic button to view the resulting circuit.

TYPICAL APPLICATIONS

22kHz, 5th Order, 0.1dB Ripple Chebyshev Lowpass Filter
Driving the LTC1604, 16-Bit ADC

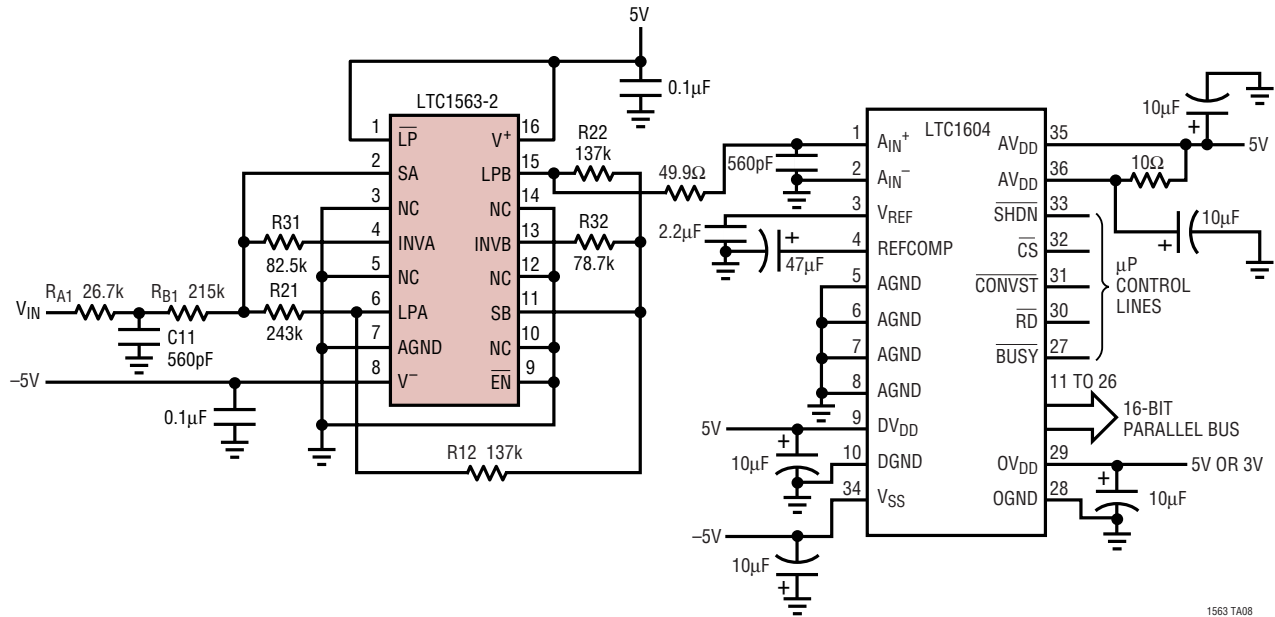

1563 TA08

4096 Point FFT of the Output Data

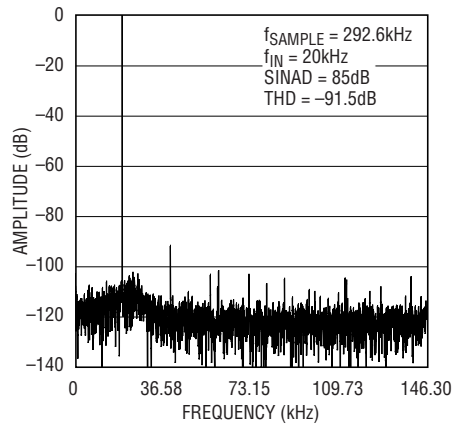

1563 TA08a

TYPICAL APPLICATIONS

50kHz Wideband Bandpass

4th Order Bessel Lowpass at 128kHz with Two Highpass Poles at 11.7kHz Yields a Wideband Bandpass Centered at 50kHz

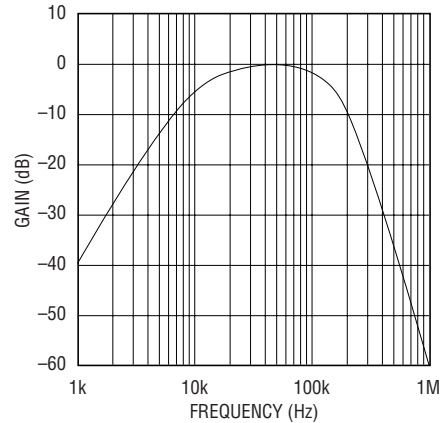
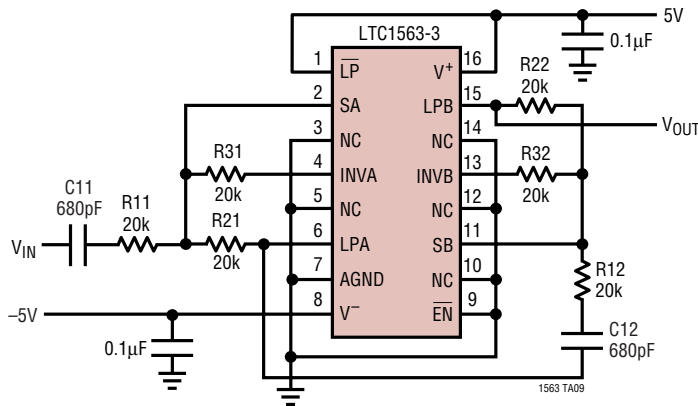

1563 TA09a

To design these wideband bandpass filters with the LTC1563, start with a 4th order lowpass filter and add two highpass poles with the input, AC coupling capacitors. The lowpass cutoff frequency and highpass pole frequencies depend on the specific application. Some experimentation of lowpass and highpass frequencies is required to achieve the desired response. FilterCAD does not directly support this configuration. Use the custom design window in FilterCAD get the desired response and then use FilterCAD to give the schematic for the lowpass portion of the filter. Calculate the two highpass poles using the following formulae:

$$f_0(\text{HPA}) = \frac{1}{2 \cdot \pi \cdot R11 \cdot C11}, \quad f_0(\text{HPB}) = \frac{1}{2 \cdot \pi \cdot R12 \cdot C12}$$

The design process is as follows:

1. After starting FilterCAD, select the Enhanced Design window.
2. Choose a 4th order Bessel or Butterworth lowpass filter response and set the cutoff frequency to the high frequency corner of the desired bandpass.
3. Click on the custom response button. This copies the lowpass coefficients into the custom design Coefficients table.

4. In the Coefficients table, the first two rows are the LP Type with the f_0 and Q as previously defined. Go to the third and fourth rows and click on the Type column (currently a hyphen is in this space). Change the Type of each of these rows to type HP1. This sets up a template of a 6th order filter with two 2nd order lowpass sections and two 1st order highpass sections.
5. Change the frequency of the highpass (HP1) poles to get the desired frequency response.
6. You may have to perform this loop several times before you close in on the correct response.
7. Once you have reached a satisfactory response, note the highpass pole frequencies. The HP1 highpass poles must now be removed from the Custom design coefficients table. After removing the highpass poles, click on the Implement button to go on to the filter implementation stage.
8. In the Enhanced Implement window, click on the Active RC button and choose the LTC1563-2 part. Click on the schematic button to view the resulting circuit.
9. You now have the schematic for the 4th order lowpass part of the design. Now calculate the capacitor values from the following formulae:

$$C11 = \frac{1}{2 \cdot \pi \cdot R11 \cdot f_0(\text{HPA})}, \quad C12 = \frac{1}{2 \cdot \pi \cdot R12 \cdot f_0(\text{HPB})}$$

156323fa

TYPICAL APPLICATIONS

150kHz, 0.5dB Ripple, 4th Order Chebyshev with 10dB of DC Gain

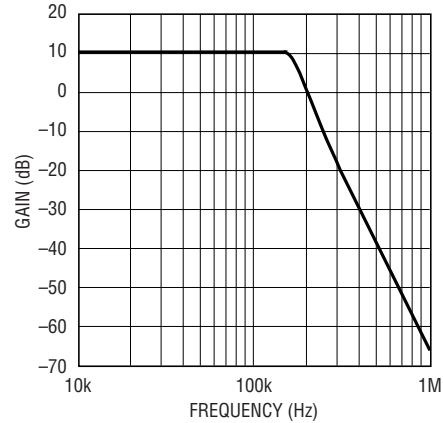
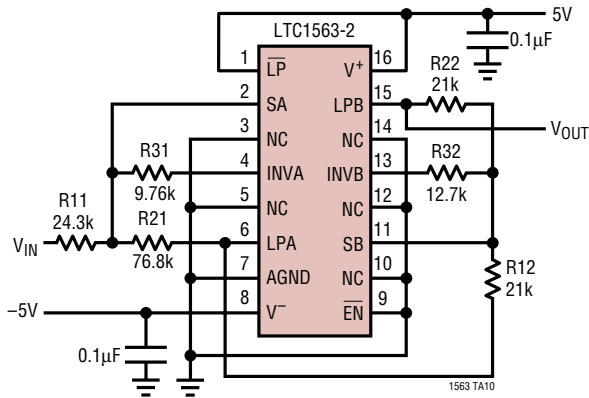

PACKAGE DESCRIPTION

Dimensions in inches (millimeters) unless otherwise noted.

GN Package
16-Lead Plastic SSOP (Narrow 0.150)
 (LTC DWG # 05-08-1641)

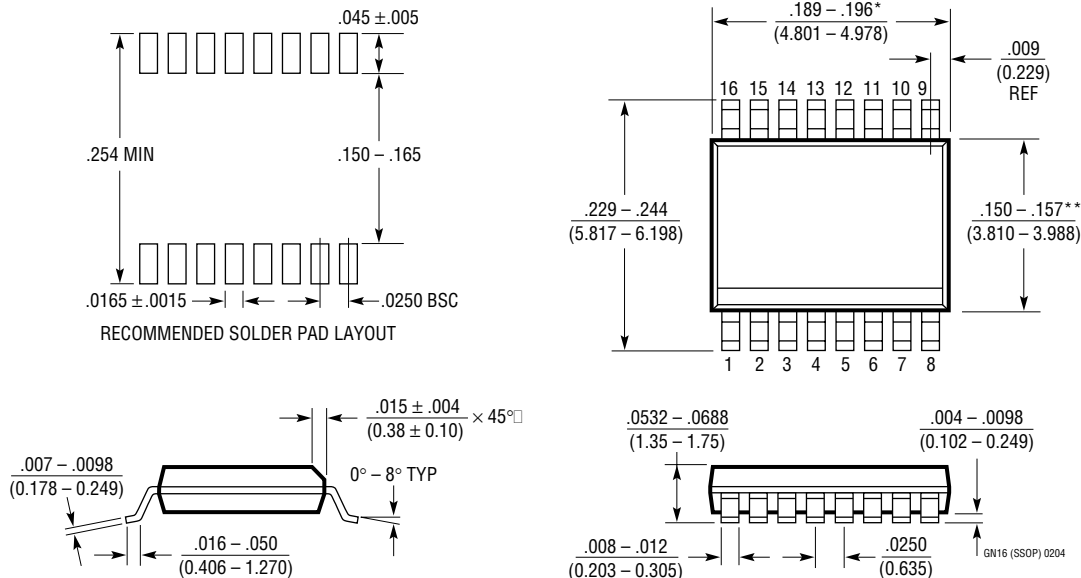

- NOTE:
1. CONTROLLING DIMENSION: INCHES
 2. DIMENSIONS ARE IN $\frac{\text{INCHES}}{\text{MILLIMETERS}}$
 3. DRAWING NOT TO SCALE
- *DIMENSION DOES NOT INCLUDE MOLD FLASH. MOLD FLASH SHALL NOT EXCEED 0.006" (0.152mm) PER SIDE
- **DIMENSION DOES NOT INCLUDE INTERLEAD FLASH. INTERLEAD FLASH SHALL NOT EXCEED 0.010" (0.254mm) PER SIDE

156323fa

TYPICAL APPLICATIONS

Single Supply, 10kHz, Bandpass Filter
 Maximum $f_{center} = 120\text{kHz}$ (-3dB Bandwidth = $f_{center}/10$)

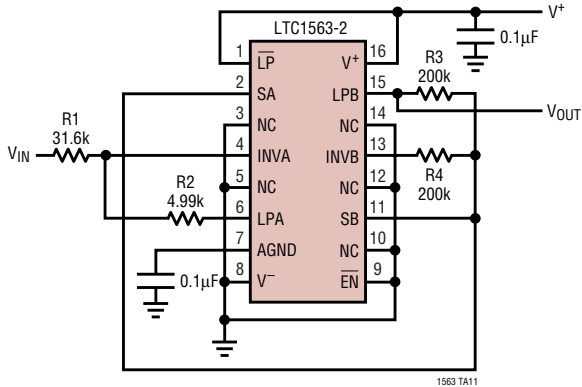

GAIN AT $f_{CENTER} = \frac{31.6k}{R1}$ MAXIMUM GAIN = $120\text{kHz}/f_{CENTER}$
 $R2 = 4.99k$
 $R3 = R4 = R$

$$R = \frac{10^{21}}{f_{CENTER} \cdot (f_{CENTER}^2 + 5 \cdot 10^{11})}$$

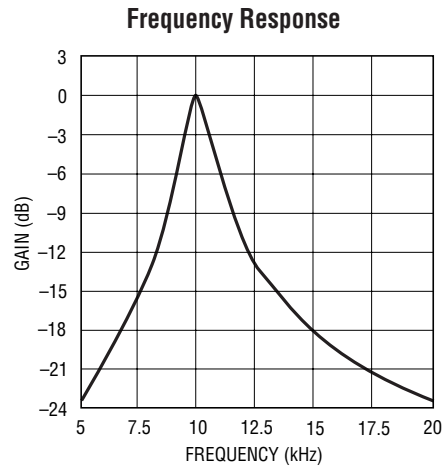

Single Supply, 100kHz, Elliptic Lowpass Filter
 Maximum $f_{cutoff} = 120\text{kHz}$

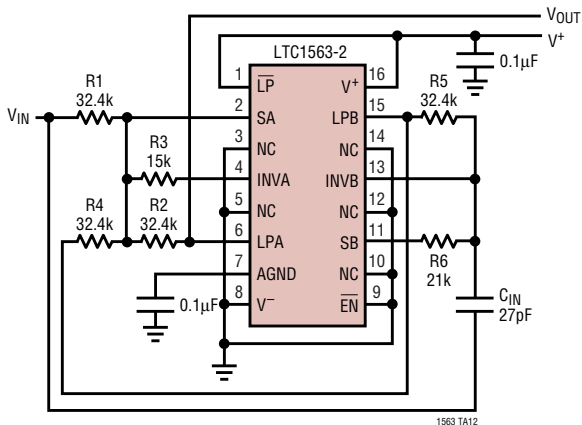

PASSBAND GAIN = 0dB
 STOPBAND ATTENUATION = 26dB AT $1.5X f_{CUTOFF}$
 $C_{IN} = 27\text{pF}$ $R2 = R4 = R5 = R1$

$$R1 = \frac{3.24 \cdot 10^9}{f_{CUTOFF}} \quad R3 = \frac{R1}{2.16} \quad R6 = \frac{R1}{1.54}$$

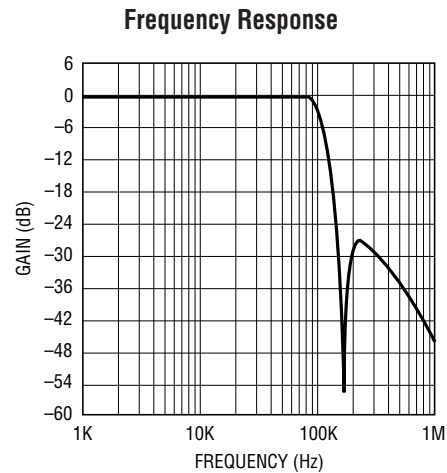

RELATED PARTS

PART NUMBER	DESCRIPTION	COMMENTS
LTC1560-1	5-Pole Elliptic Lowpass, $f_c = 1\text{MHz}/0.5\text{MHz}$	No External Components, SO-8
LTC1562	Universal Quad 2-Pole Active RC	$10\text{kHz} < f_0 < 150\text{kHz}$
LTC1562-2	Universal Quad 2-Pole Active RC	$20\text{kHz} < f_0 < 300\text{kHz}$
LTC1569-6	Low Power 10-Pole Delay Equalized Elliptic Lowpass	$f_c < 80\text{kHz}$, One Resistor Sets f_c , SO-8
LTC1569-7	10-Pole Delay Equalized Elliptic Lowpass	$f_c < 256\text{kHz}$, One Resistor Sets f_c , SO-8
LTC1565-31	650kHz Continuous Time, Linear Phase Lowpass	$f_c = 650\text{kHz}$, Differential In/Out
LTC1568	Very Low Noise 4 th Order Filter Building Block	$f_c < 10\text{MHz}$

1563231a